

# POWERLINE <sup>USA</sup>

by *Body-Solid*

## PLA144X

### LAT ROW STATION

### OWNER'S MANUAL

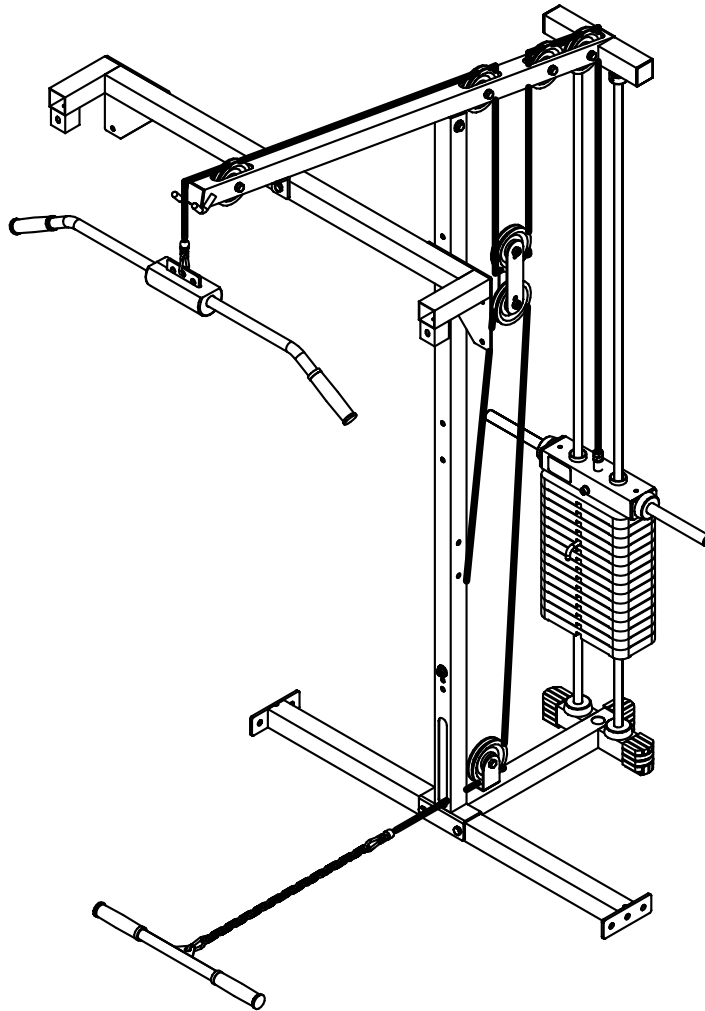

[WWW.BODYSOLID.COM](http://WWW.BODYSOLID.COM)

V. PLA144X\_122211

**THERE IS A RISK ASSUMED BY INDIVIDUALS WHO USE THIS TYPE OF EQUIPMENT. TO MINIMIZE RISK, YOU MUST FOLLOW THESE RULES:**

Inspect equipment before each workout. Check that all nuts, bolts, screws and pop pins are in place and fully tightened. Also, before use, check cables for sign of wear. Replace all worn parts immediately. Never use machine if any parts are damaged or missing.

**FAILURE TO FOLLOW THESE RULES MAY RESULT IN SERIOUS INJURY.**

Keep clear of the cables and all moving parts when machine is in use.

Always make sure all Snap Links are closed when doing cable/pulley/strap exercises.

Exercise with care. Perform your exercises at a smooth moderate pace; never perform jerky or uncoordinated movements that may cause injury.

It is recommended that you workout with a training partner.

Do not allow children or minors to play on or around this equipment.

If unsure of proper use of equipment, call your local Body-Solid distributor or the Body-Solid customer service center at 1-800-556-3113.

**WARNING:** Consult your physician before starting your exercise program. For your own safety, do not begin any exercise program without proper instruction.

## **WARNING**

### **Safety and Maintenance of Cables**

**IMPORTANT:** Cables are wear items. It is your responsibility to prevent unexpected breakage.

**Cable inspection should be performed daily.**

Inspect all cables, the nylon coating on all cables, and the area near the fitting at each end of each cable.

**Replace any damaged or worn cable immediately.**

Do not allow the machine to be used until damaged or worn cables are replaced. Using or allowing a machine to be used with a suspect cable can result in serious injury. See Owner's Manual for more information.

For Body-Solid Customer Service  
**Call 1-800-556-3113**

**DO NOT REMOVE WARNING LABELS FROM  
MANUAL OR MACHINE**

# **PLA 144X**

## **TABLE OF CONTENTS**

- **SAFETY INSTRUCTIONS.....PAGE 4**
- **PREPARATION..... PAGE 5**
- **HARDWARE LIST..... PAGE 6**
- **HARDWARE ILLUSTRATION..... PAGE 7**
- **PART LIST / ILLUSTRATION.....PAGE 11**
- **ASSEMBLY INSTRUCTIONS..... PAGE 12**
- **EXPLODED VIEW..... PAGE 20**
- **CONTACT PAGE.....PAGE 22**

# PLA 144X

## SAFETY INSTRUCTIONS

**WHEN USING EXERCISE EQUIPMENT,  
YOU SHOULD ALWAYS TAKE BASIC  
PRECAUTIONS INCLUDING THE  
FOLLOWING:**

- Read all instructions before using the PLA144X. These instructions are written to ensure your safety and to protect the unit.
- **Do not remove any safety labels from the machine.**
- Do not allow children on or near the equipment.
- Use the equipment only for its intended purpose as described in this guide. Do not use accessory attachments that are not recommended by the manufacturer. Such attachments might cause serious injuries.
- Wear proper exercise clothing and shoes for your workout, no loose clothing.
- Keep hands, limbs, loose clothing, and long hair well out of the way of all moving parts
- Use care when getting on or off the unit.
- Do not overexert yourself or work to exhaustion.
- If you feel any pain or abnormal symptoms, stop your workout immediately and consult your physician.
- Never operate unit when it has been dropped or damaged. Return the equipment to a service center for examination and repair.
- Never drop or insert objects into any opening in the equipment.
- Always check the unit and its cables before each use. Make sure that all fasteners and cables are secure and in good working condition.
- Do not use the equipment outdoors or near water.

**PERSONAL SAFETY DURING ASSEMBLY**

- Before beginning assembly, please take the time to read the instructions thoroughly.
- Read each step in the assembly instructions and follow the steps in sequence. Do not skip ahead. If you skip ahead, you may learn later that you have to disassemble components and that you may have damaged the equipment
- Assemble and operate the PLA144X on a solid, level surface. Locate the unit a few feet from the walls or furniture to provide easy access.

The PLA144X is designed for your enjoyment. By following these precautions and using common sense, you will have many safe and pleasurable hours of healthful exercise with your Powerline Lat Row Station.

After assembly, you should check all functions to ensure correct operation. If you experience problems, first recheck the assembly instructions to locate any possible errors made during assembly. If you are unable to correct the problem, call the dealer from whom you purchased the machine or call 1-800-556-3113 for the dealer nearest you.

**OBTAINING SERVICE**

Please use this Owner's Manual to make sure that all parts have been included in your shipment. When ordering parts, you must use the part number and description from this Owner's Manual. Use only Powerline by Body Solid replacement parts when servicing this machine. Failure to do so will void your warranty and could result in personal injury.

For information about product operation or service, check out the official Powerline website at [www.bodysolid.com](http://www.bodysolid.com) or contact an authorized Powerline dealer or a Powerline factory-authorized service company or contact Body-Solid customer service at one of the following:

Toll Free: 1-800-556-3113  
Phone: 1-708-427-3555  
Fax: 1-708-427-3556  
Email: [service@bodysolid.com](mailto:service@bodysolid.com)

Or write to: Body-Solid, Inc.  
Service Department  
1900 S. Des Plaines Ave.  
Forest Park, IL 60130 USA

**RETAIN THIS OWNER'S MANUAL FOR  
FUTURE REFERENCE. PART NUMBERS  
ARE REQUIRED WHEN ORDERING PARTS.**

# PLA 144X

## PREPARATION

### REQUIRED TOOLS

The basic tools that you must obtain before assembling the PLA144X include but are not limit to:

- Standard Wrench Set
- Metric Wrench Set
- Adjustable Wrench
- Standard / Metric Allen Key Set

### INSTALLATION REQUIREMENTS

Follow these installation requirements when assembling the PLA144X:

Set up the PLA144X on a solid, flat surface. A smooth, flat surface under the machine helps keep it level.

Provide ample space around the machine. Open space around the machine allows for easier access.

For aesthetic purposes, insert all bolts in the same direction unless specified (in text or illustrations) to do otherwise.

Leave room for adjustments. Tighten fasteners such as bolts, nuts, and screws so the unit is stable, but leave room for adjustments. Do not fully tighten fasteners until instructed in the assembly steps to do so.

Fill out and mail the warranty card.

### ORDERING REPLACEMENT PARTS

If you need to order replacement parts please be prepared to provide the following information when contacting us so that we can assist you better.

1. Model Number
2. Place of Purchase
3. Serial Number (S/N)
4. Part # and Description

### ASSEMBLY TIPS

Read all "Notes" on each page before beginning each step.

While you may be able to assemble the PLA144X using the illustrations only, important safety notes and other tips may be included in the text.

Some pieces may have extra holes that you will not use. Use only those holes indicated in the instructions and illustrations.

**NOTE:** With so many assembled parts, proper alignment and adjustment is critical. While tightening the nuts and bolts, be sure to leave room for adjustments.

**NOTE:** The bottles that are marked "Poison" is your touch up paint. Keep away from children.

**CAUTION:** Obtain assistance! If you feel like you can't assemble the PLA144X by yourself then do not attempt to do so as this could result in injury. Review the Installation Requirements before proceeding with the following steps.

**YOUR S/N # CAN  
BE FOUND HERE**

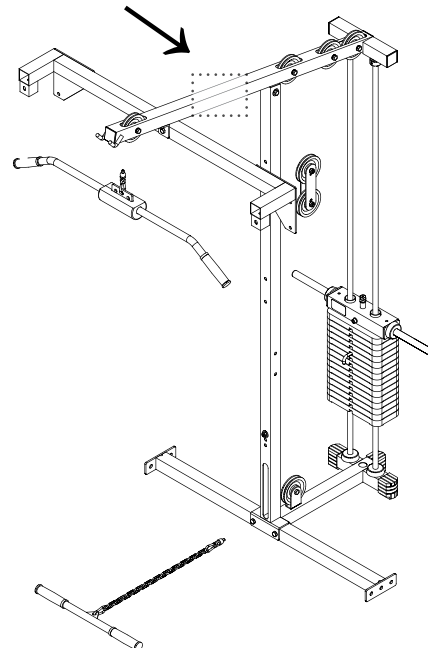

# PLA 144X

## HARDWARE LIST

<u>PART #</u>	<u>SIZE</u>	<u>DESCRIPTION</u>	<u>QUANTITY</u>
1	M10X75mm	HEX HEAD BOLT	2 PCS.
2	M10X70mm	HEX HEAD BOLT	1 PCS.
3	M10X65mm	HEX HEAD BOLT	6 PCS.
4	M10X40mm	HEX HEAD BOLT	3 PCS.
5	3/8"X3 1/2"	ALLEN HEAD BOLT	1 PCS.
6	M10	NYLON LOCK NUT	12 PCS.
7	1/2"	LOCK NUT	1 PCS.
8	3/8"	NYLON LOCK NUT	1 PCS.
9	M10	LARGE WASHER	5 PCS.
10	M10	SMALL WASHER	2 PCS.
11	1/2"	SPRING WASHER	1 PCS.
12	50X50mm	FOOT CAP	3 PCS.
13	50X50mm	END CAP	4 PCS.
14	16mm	STEEL BUSHING	8 PCS.
15	25X135mm	RUBBER GRIP	4 PCS.
16	2 1/2"	LARGE DONUT	2 PCS.
17	2 1/2"	SMALL DONUT	2 PCS.
18	110mm	PULLEY	7 PCS.
19	6mm	SNAP LINK	3 PCS.
20	3/4"	SHAFT COLLAR	2 PCS.
21		STEEL CHAIN	1 PCS.
22		POP PIN	1 PCS.
23		SELECTOR ROD	1 PCS.
24	3310mm	LAT CABLE	1 PCS.
25	2965mm	ROW CABLE	1 PCS.

# PLA 144X

## HARDWARE ILLUSTRATION

**PART #1**                      **M10X75MM HEX HEAD BOLT**                      **QTY. 2**

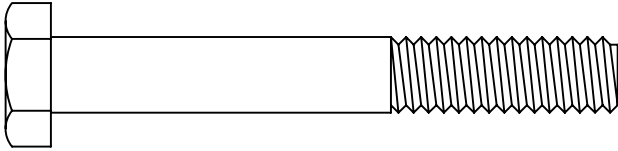

**PART #2**                      **M10X70MM HEX HEAD BOLT**                      **QTY. 1**

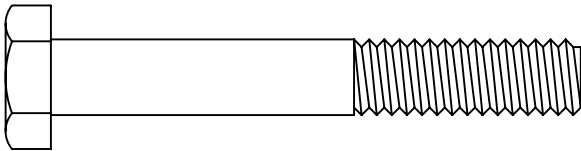

**PART #3**                      **M10X65MM HEX HEAD BOLT**                      **QTY. 6**

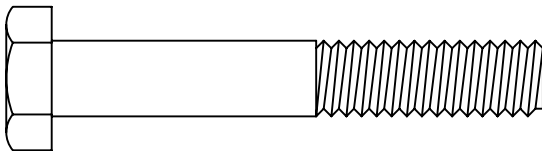

**PART #4**                      **M10X40MM HEX HEAD BOLT**                      **QTY. 3**

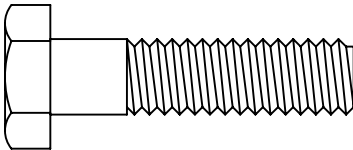

**PART #5**                      **3/8"X3 1/2" ALLEN HEAD BOLT**                      **QTY. 1**

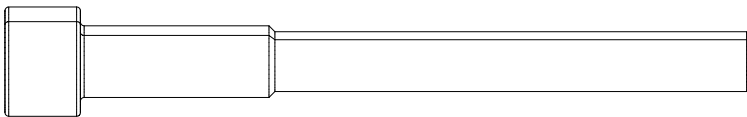

**PART #6**                      **M10 NYLON LOCK NUT**                      **QTY. 12**

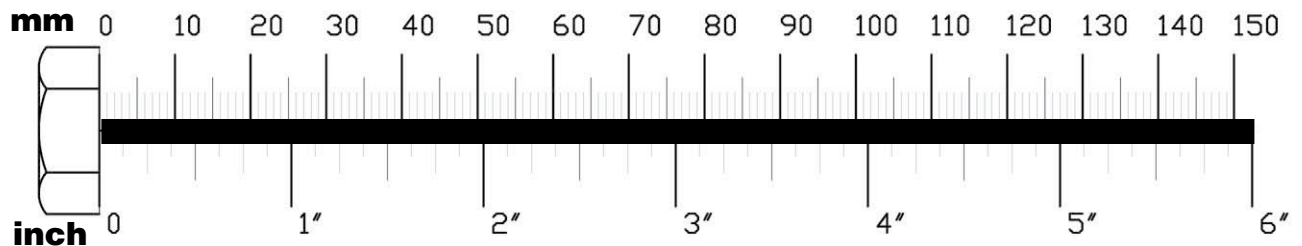
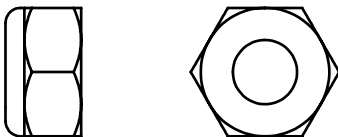

# PLA 144X

## HARDWARE ILLUSTRATION CONT.

PART #7

1/2" NYLON LOCK NUT

QTY. 1



PART #8

3/8" NYLON LOCK NUT

QTY. 1

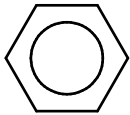

PART #9

M10 LARGE WASHER

QTY. 5

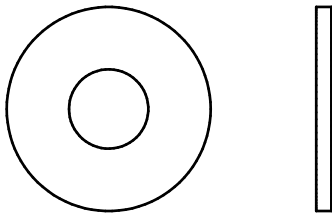

PART #10

M10 SMALL WASHER

QTY. 2

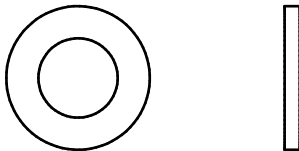

PART #11

1/2" SPRING WASHER

QTY. 1

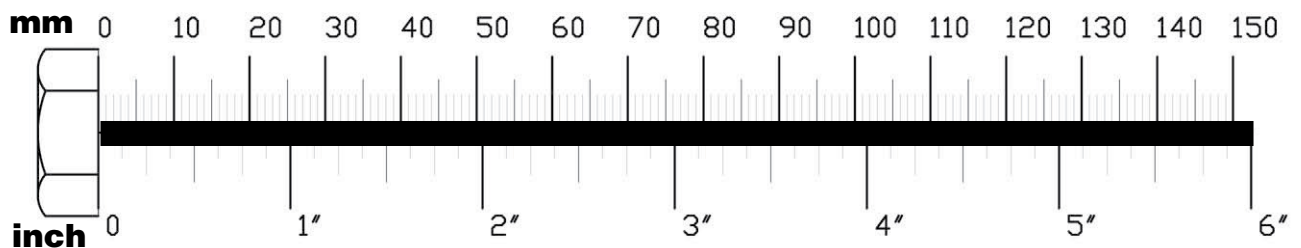
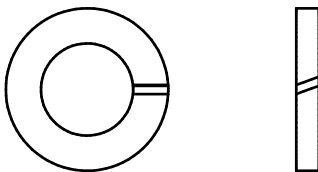



# PLA144X

## HARDWARE ILLUSTRATION

**PART # 12**                      **50X50MM FOOT CAP**                      **QTY. 3**

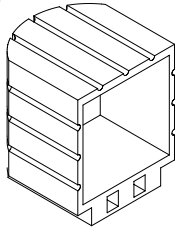

**PART # 13**                      **50X50MM END CAP**                      **QTY. 4**

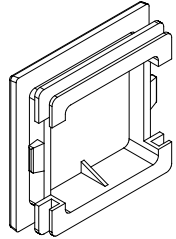

**PART # 14**                      **16MM STEEL BUSHING**                      **QTY. 8**

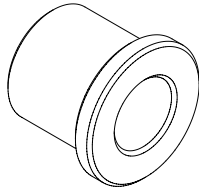

**PART # 15**                      **25X135MM RUBBER GRIP**                      **QTY. 4**

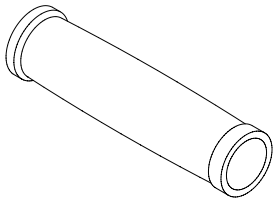

**PART # 16**                      **2 1/2" LARGE DONUT**                      **QTY. 2**

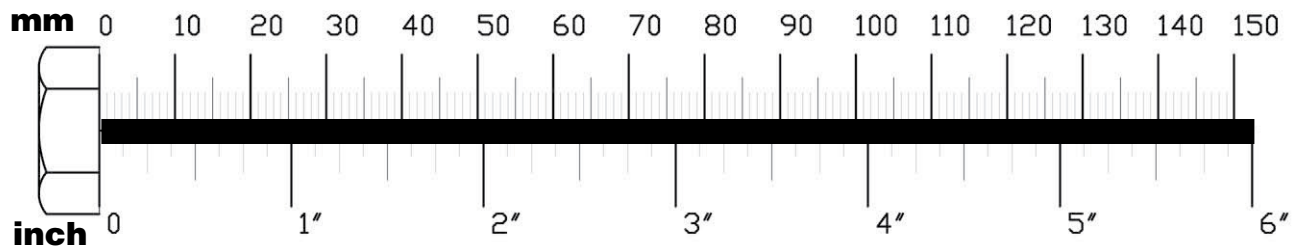
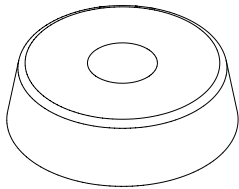

# PLA 144X

## HARDWARE ILLUSTRATION CONT.

PART #17

2 1/2" SMALL DONUT

QTY. 2

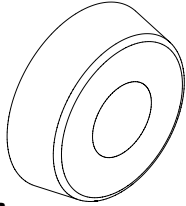

PART #18

110MM PULLEY

QTY. 7

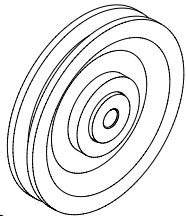

PART #19

6MM SNAP LINK

QTY. 3

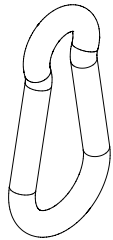

PART #20

3/4" SHAFT COLLAR

QTY. 2

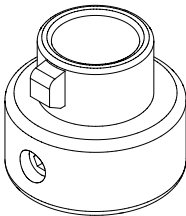

PART #23

SELECTOR ROD

QTY. 1

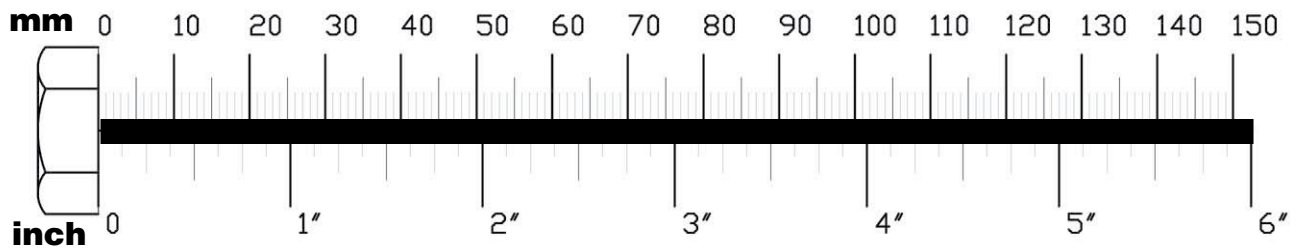
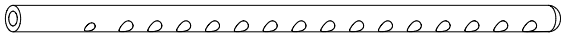

# PLA 144X

PART LIST

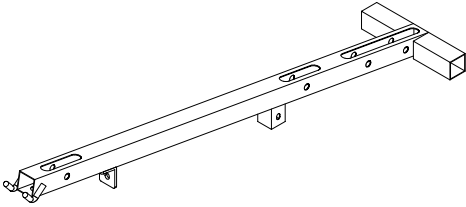

**PART A**  
TOP FRAME  
[1 PCS]

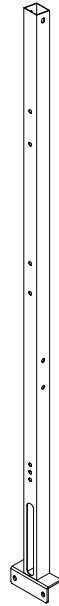

**PART B**  
VERTICAL FRAME  
[1 PCS]

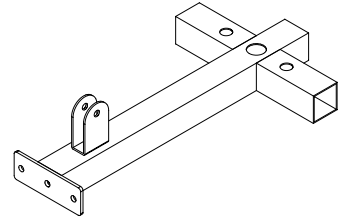

**PART C**  
BASE FRAME  
[1 PCS]

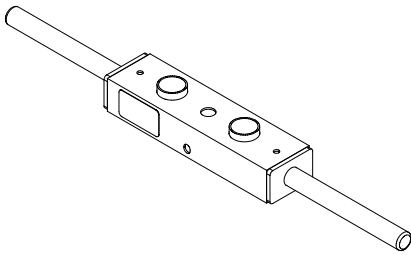

**PART D**  
TOP PLATE  
[1 PCS]

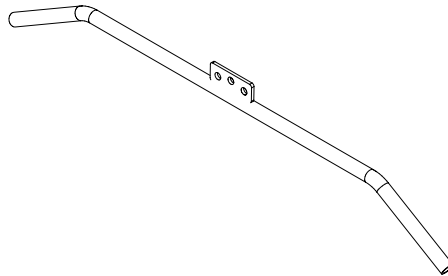

**PART E**  
LAT BAR  
[1 PCS]

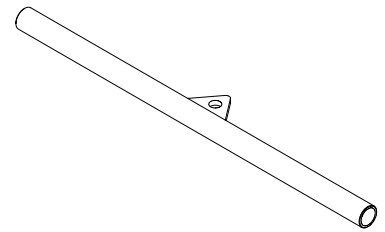

**PART F**  
ROW BAR  
[1 PCS]



**PART G**  
PULLEY PLATE  
[2 PCS]

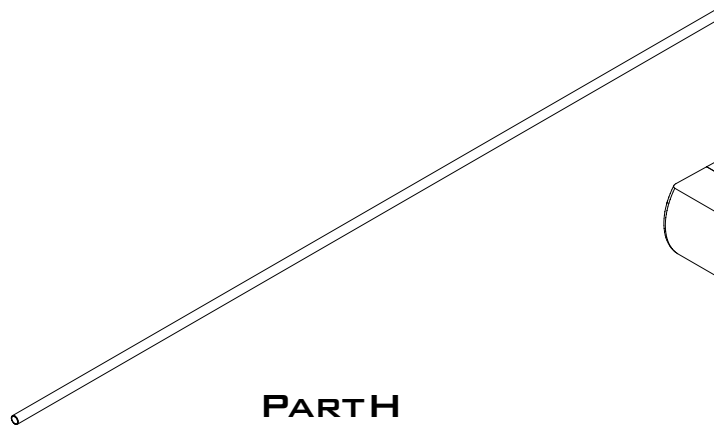

**PART H**  
GUIDE ROD  
[1 PCS]

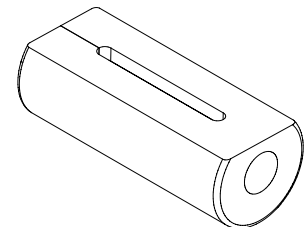

**PART I**  
LAT BAR PAD  
[1 PCS]

# PLA 144X

## STEP 1

**BE CAREFUL TO ASSEMBLE ALL COMPONENTS IN THE SEQUENCE THAT THEY ARE PRESENTED.**

**NOTE:**

FINGER TIGHTEN ALL HARDWARE IN THIS STEP. DO NOT WRENCH TIGHTEN UNTIL THE LAST STEP. SOME COMPONENTS MAY BE PRE-ASSEMBLED.

NYLON LOCK NUTS WILL NOT FULLY SCREW ONTO BOLTS, MUST WRENCH TIGHTEN.

- 1 A. ATTACH VERTICAL FRAME (B) AND BASE FRAME (C) TO THE BACK FRAME OF YOUR PSM144X USING:
  - 2 - (#1) M10X75MM HEX HEAD BOLT
  - 2 - (#6) M10 NYLON LOCK NUT
  
- 1 B. INSERT A FOOT CAP ONTO EACH END OPENING OF BASE FRAME (C) USING:
  - 3 - (#12) 50X50MM FOOT CAP
  
- 1 C. INSERT EACH CHROME GUIDE ROD (H) THRU A LARGE RUBBER DONUT AND INTO BASE FRAME (C) USING:
  - 2 - (#16) 2 1/2" LARGE RUBBER DONUT
  
- 1 D. SLIDE ALL WEIGHT PLATES ONTO CHROME GUIDE RODS (H).
  
- 1 E. ATTACH SELECTOR ROD (#23) TO TOP PLATE (D) USING:
  - 1 - (#5) 3/8"X3 1/2" ALLEN HEAD BOLT
  - 2 - (#10) M10 SMALL WASHER
  - 1 - (#8) 3/8" NYLON LOCK NUT
  
- 1 F. SLIDE A SMALL RUBBER DONUT (#17) ONTO EACH POST END OF TOP PLATE (D).
  
- 1 G. INSERT TOP PLATE (D) ONTO CHROME GUIDE RODS (H) AND SECURE SELECTOR ROD (#23) TO WEIGHT PLATES USING POP PIN (#22).

# PLA 144X

## STEP 1

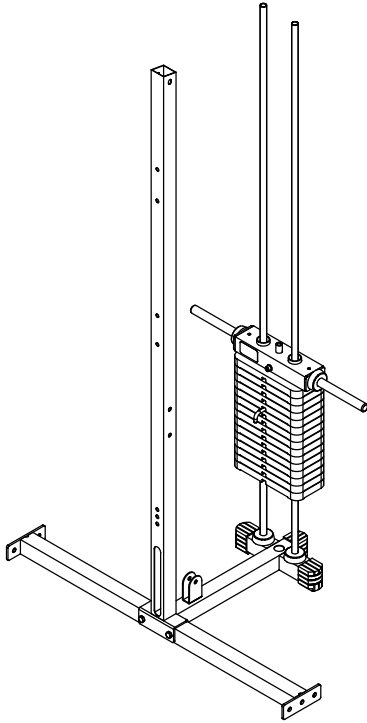

ABOVE SHOWS STEP 1  
ASSEMBLED AND COMPLETED

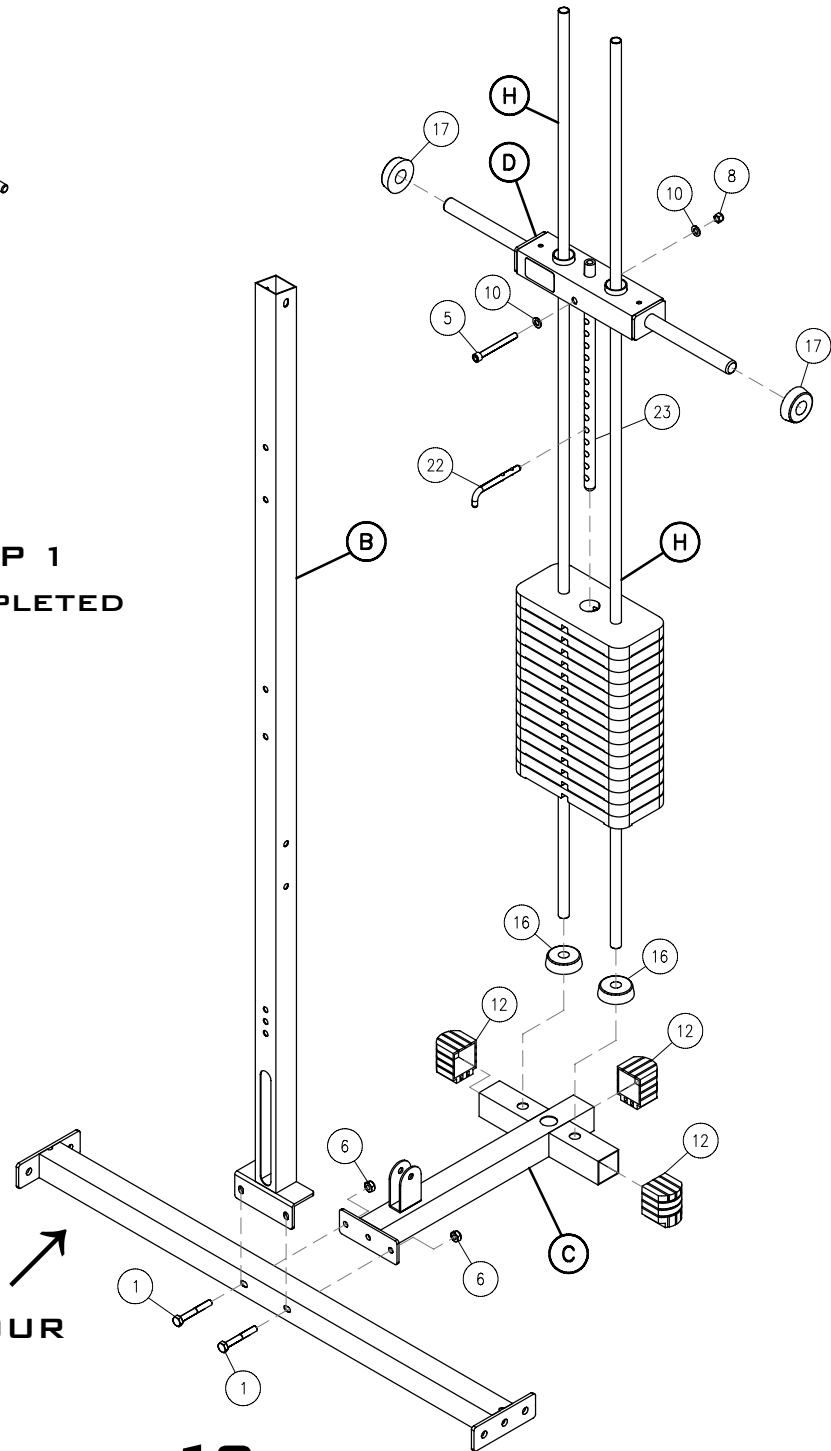

BACK FRAME OF YOUR  
PSM144X

# PLA 144X

## STEP 2

**BE CAREFUL TO ASSEMBLE ALL COMPONENTS IN THE SEQUENCE THAT THEY ARE PRESENTED.**

**NOTE:**

FINGER TIGHTEN ALL HARDWARE IN THIS STEP. DO NOT WRENCH TIGHTEN UNTIL THE LAST STEP. SOME COMPONENTS MAY BE PRE-ASSEMBLED.

NYLON LOCK NUTS WILL NOT FULLY SCREW ONTO BOLTS, MUST WRENCH TIGHTEN.

**2A. SLIDE A 3/4" SHAFT COLLAR (#20) ONTO EACH CHROME GUIDE ROD (H). SECURE THE GUIDE RODS BY INSERTING THE SHAFT COLLAR / GUIDE ROD INTO THE REAR BOTTOM OPENINGS OF TOP FRAME (A) AND TIGHTEN ALLEN BOLTS.**

**2B. ATTACH TOP FRAME (A) TO VERTICAL FRAME (B) USING:**

**1 - (#3) M10X65MM HEX HEAD BOLT**

**2 - (#9) M10 LARGE WASHER**

**1 - (#6) M10 NYLON LOCK NUT**

**2C. ATTACH TOP FRAME (A) TO THE TOP FRAME OF YOUR PSM144X USING:**

**1 - (#2) M10X70MM HEX HEAD BOLT**

**1 - (#9) M10 LARGE WASHER**

**1 - (#6) M10 NYLON LOCK NUT**

**2D. ATTACH A 110MM PULLEY (#18) TO THE PULLEY HOLDER ON BASE FRAME (C) USING:**

**1 - (#4) M10X40MM HEX HEAD BOLT**

**1 - (#6) M10 NYLON LOCK NUT**

**2E. INSERT A 50X50MM END CAP (#13) INTO EACH OPENING OF TOP FRAME (A). 4 TOTAL TO BE USED.**

**2F. ASSEMBLE ROW BAR (F) BY INSERTING A 25X135MM RUBBER GRIP (#15) ON EACH SIDE. ATTACH A SNAP LINK (#19) TO THE EYE HOLE OF ROW BAR (F) FOLLOWED BY THE STEEL CHAIN AND ANOTHER SNAP LINK.**

# PLA144X

## STEP 2

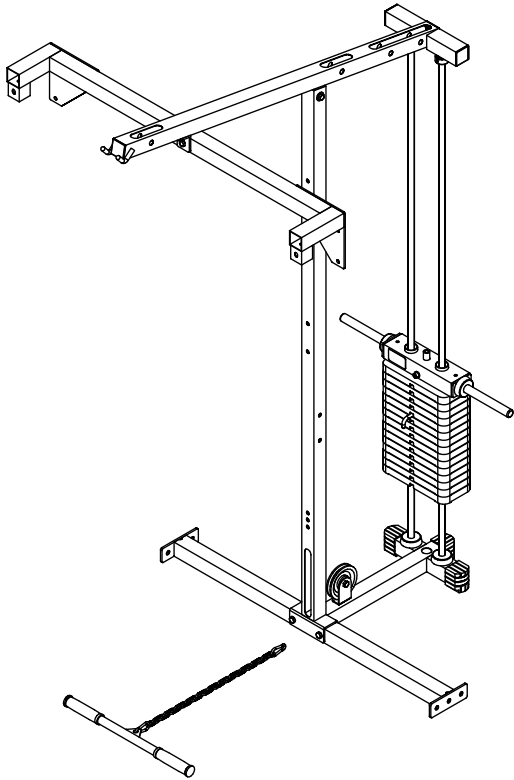

ABOVE SHOWS STEP 2  
ASSEMBLED AND COMPLETED

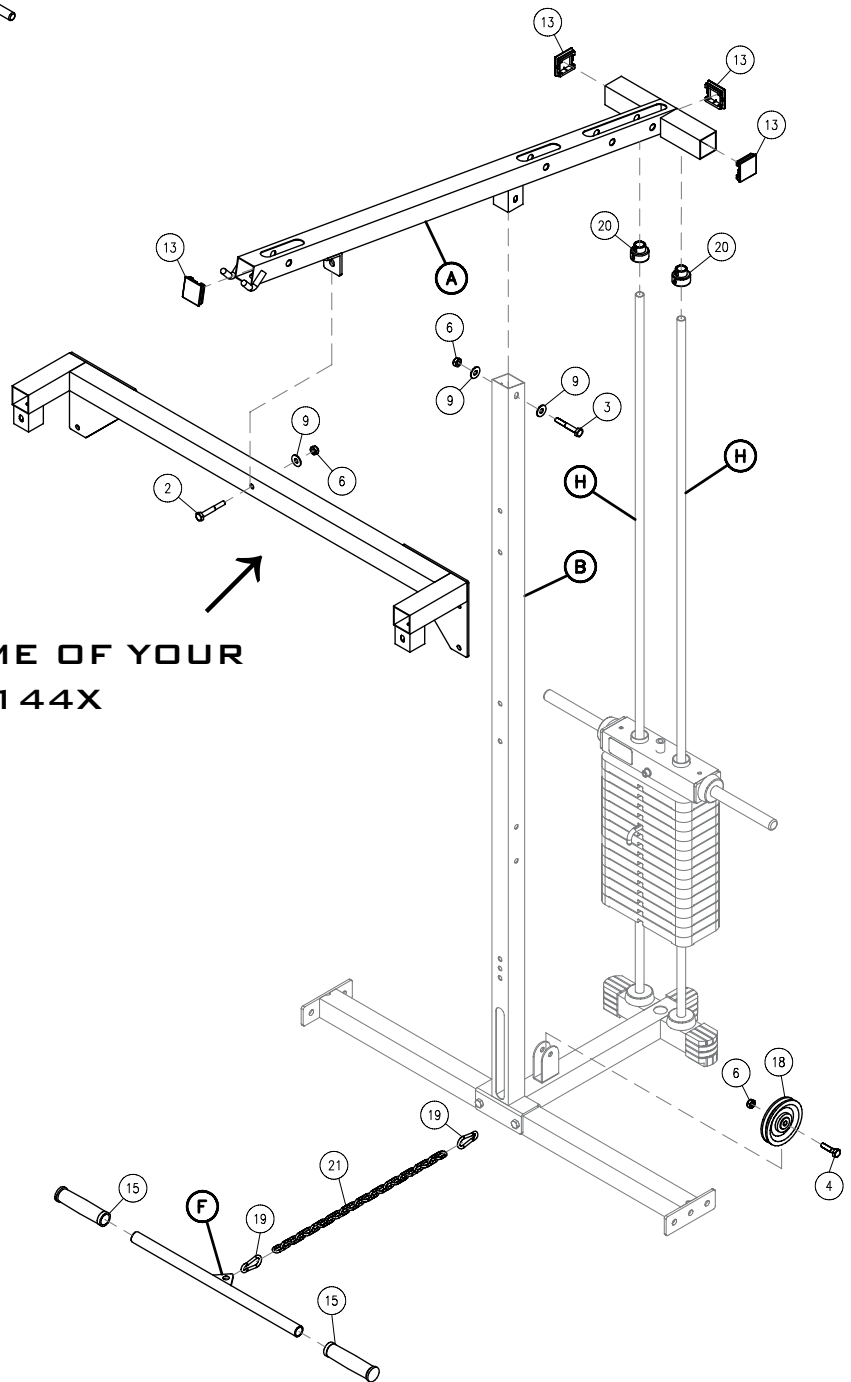

TOP FRAME OF YOUR  
PSM144X

# PLA 144X

## STEP 3

**BE CAREFUL TO ASSEMBLE ALL COMPONENTS IN THE SEQUENCE THAT THEY ARE PRESENTED.**

**NOTE:**

THIS STEP IS TO SHOW YOU WHERE THE PULLEYS NEED TO BE INSTALLED AND WHAT HARDWARE YOU WILL NEED IN ORDER TO INSTALL THEM. YOU MUST INSTALL THE PULLEYS WHILE YOU ROUTE THE CABLES. CABLE ROUTING IS FOUND ON THE NEXT STEP.

**3A. ATTACH A 110MM PULLEY (#18) TO THE FRONT OF TOP FRAME (A) USING:**

- 1 - (#3) M10X65MM HEX HEAD BOLT**
- 2 - (#14) 16MM STEEL BUSHING**
- 1 - (#6) M10 NYLON LOCK NUT**

**3B. ATTACH A 110MM PULLEY (#18) TO THE MIDDLE OF TOP FRAME (A) USING:**

- 1 - (#3) M10X65MM HEX HEAD BOLT**
- 2 - (#14) 16MM STEEL BUSHING**
- 1 - (#6) M10 NYLON LOCK NUT**

**3C. ATTACH TWO 110MM PULLEYS (#18) TO THE REAR OF TOP FRAME (A) USING:**

- 2 - (#3) M10X65MM HEX HEAD BOLT**
- 4 - (#14) 16MM STEEL BUSHING**
- 2 - (#6) M10 NYLON LOCK NUT**

**3D. ATTACH TWO 110MM PULLEYS (#18) IN BETWEEN BOTH PULLEY PLATES (G) USING:**

- 2 - (#4) M10X40MM HEX HEAD BOLT**
- 2 - (#6) M10 NYLON LOCK NUT**



# PLA 144X

STEP 3

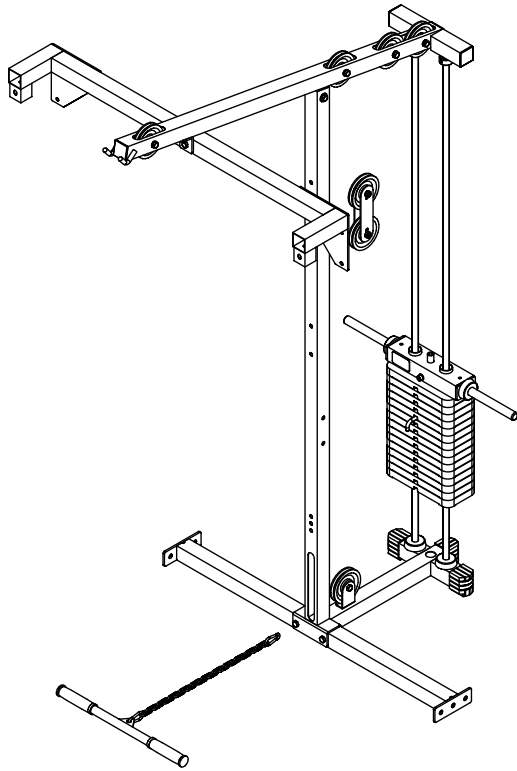

ABOVE SHOWS STEP 3  
ASSEMBLED AND COMPLETED

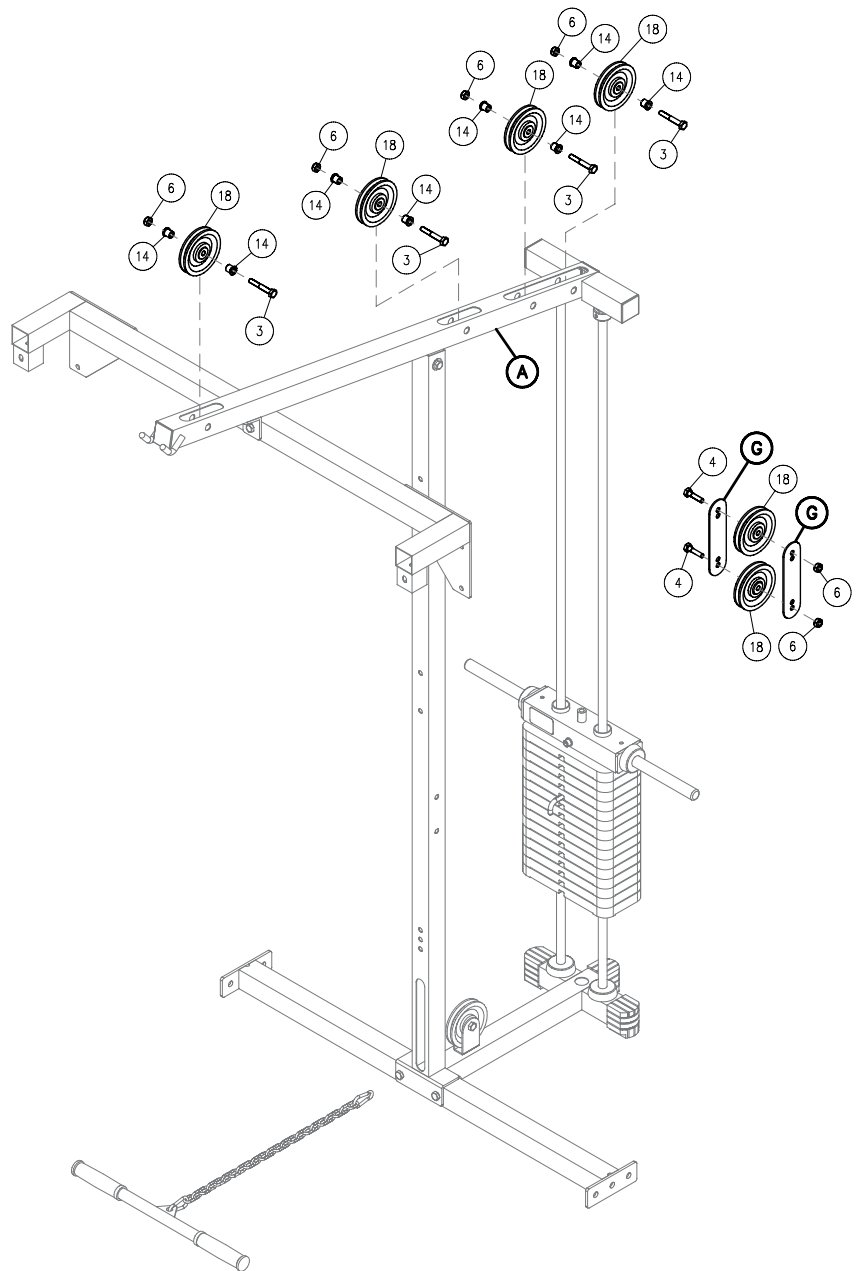

# PLA 144X

## STEP 4

**BE CAREFUL TO ASSEMBLE ALL COMPONENTS IN THE SEQUENCE THAT THEY ARE PRESENTED.**

### **NOTE:**

THIS STEP IS TO SHOW YOU HOW TO ROUTE YOUR ROW BAR AND LAT BAR CABLE. YOU WILL HAVE TO INSTALL THE PULLEYS AS SEEN IN STEP 3 AND THE CABLES AT THE SAME TIME. BE SURE TO ONLY HAND TIGHTEN THE BOLTS/NUTS FOR PULLEYS AT FIRST, DON'T FULLY TIGHTEN UNTIL ALL CABLES AND PULLEYS ARE FULLY INSTALLED.

**4A. INSERT A 25X135MM RUBBER GRIP (#15) ONTO EACH END OF LAT BAR (E). ATTACH A 6MM SNAP LINK (#19) TO THE CENTER HOLE LOCATED IN THE MIDDLE OF LAT BAR (E). LASTLY, ATTACH LAT BAR PAD (I) TO THE CENTER OF LAT BAR (E).**

**4B. LAT CABLE (#24, 3310MM), (L1) - ATTACH THE BALL END OF THE LAT CABLE TO THE SNAP LINK THAT IS HOOKED ONTO LAT BAR (E). (L2) - INSTALL THE PULLEY AND ROUTE THE CABLE OVER THE PULLEY. (L3) - INSTALL THE PULLEY AND ROUTE THE CABLE OVER THE PULLEY AND THEN DOWN TO (L4). (L4) - INSTALL THE PULLEY AND ROUTE THE CABLE AROUND THE PULLEY AND THEN UP TO (L5). (L5) - INSTALL THE PULLEY AND ROUTE THE CABLE OVER THE PULLEY AND THEN OVER TO (L6). (L6) - INSTALL THE PULLEY AND ROUTE THE CABLE OVER THE PULLEY AND THEN DOWN TO (L7). (L7) - ATTACH THE BOLT END OF THE CABLE TO THE SELECTOR ROD ALONG WITH THE 1/2" LOCK NUT (#7) AND THE 1/2" SPRING WASHER (#11).**

**4C. ROW CABLE (#25, 2965MM), (R1) - ATTACH THE BALL END OF THE ROW CABLE TO THE SNAP LINK THAT IS ATTACHED TO THE END OF THE ROW BAR CHAIN. (R2) ROUTE THE OTHER END OF THE CABLE AROUND THE ALREADY INSTALLED PULLEY AND UP TO (R3). (R3) INSTALL THE PULLEY AND ROUTE THE CABLE OVER THE PULLEY AND THEN DOWN TO (R4). (R4) ATTACH THE CABLE TO VERTICAL FRAME (B) USING:**

- 1 - (#3) M10X65MM HEX HEAD BOLT**
- 2 - (#9) M10 LARGE WASHER**
- 1 - (#6) M10 NYLON LOCK NUT**

# PLA 144X

STEP 4

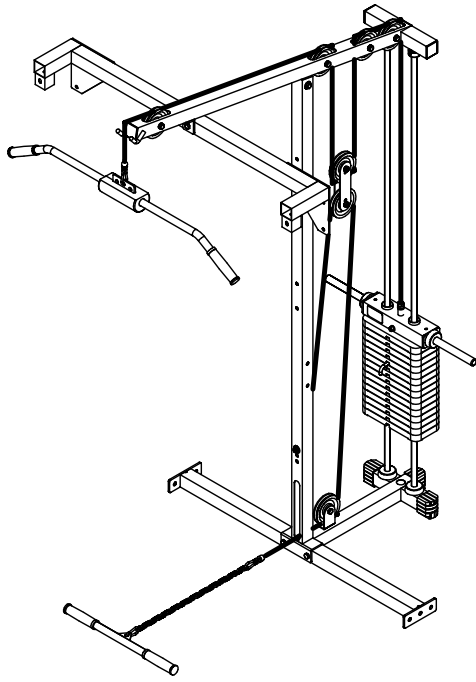

ABOVE SHOWS STEP 4  
ASSEMBLED AND COMPLETED

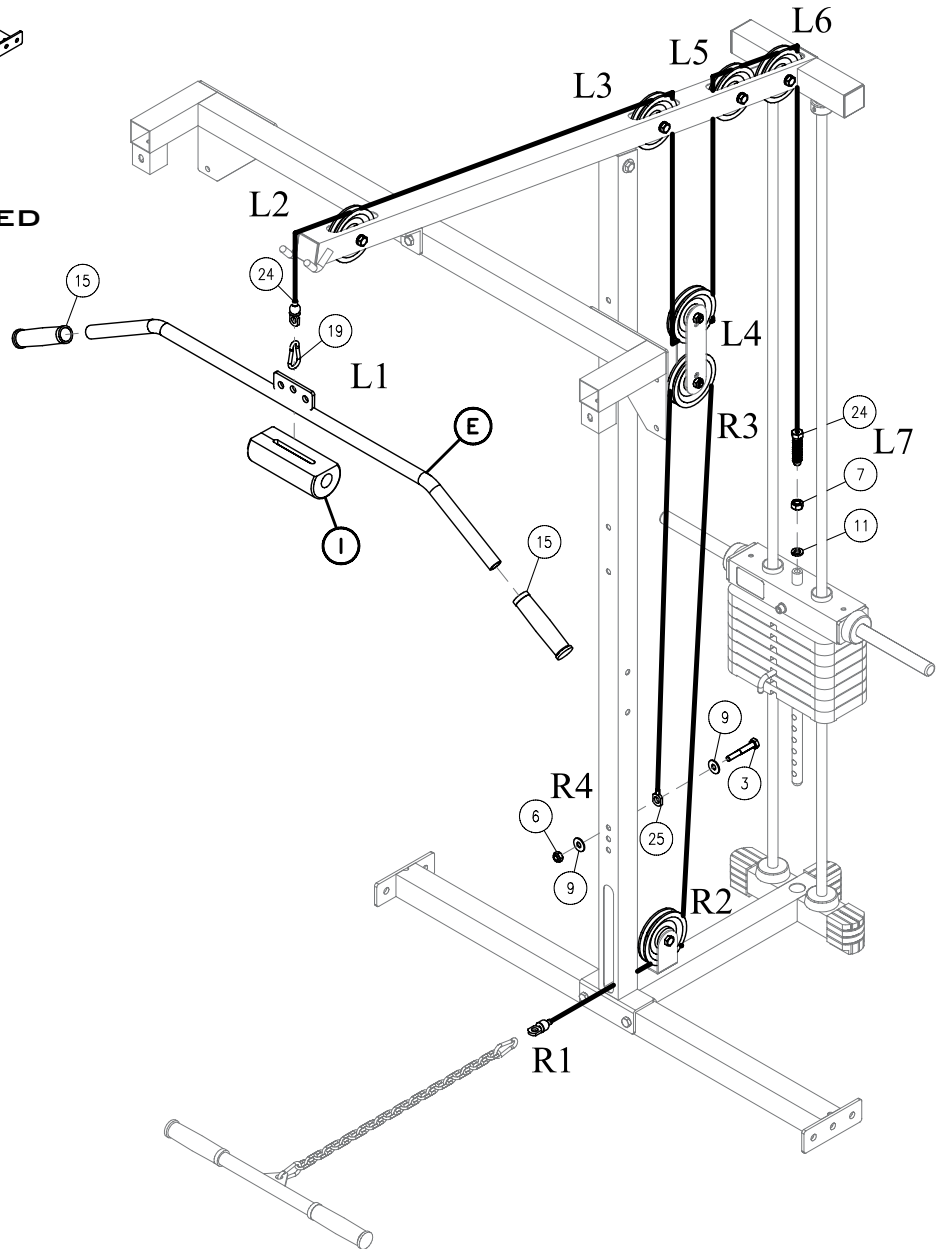

# PLA 144X

EXPLODED VIEW

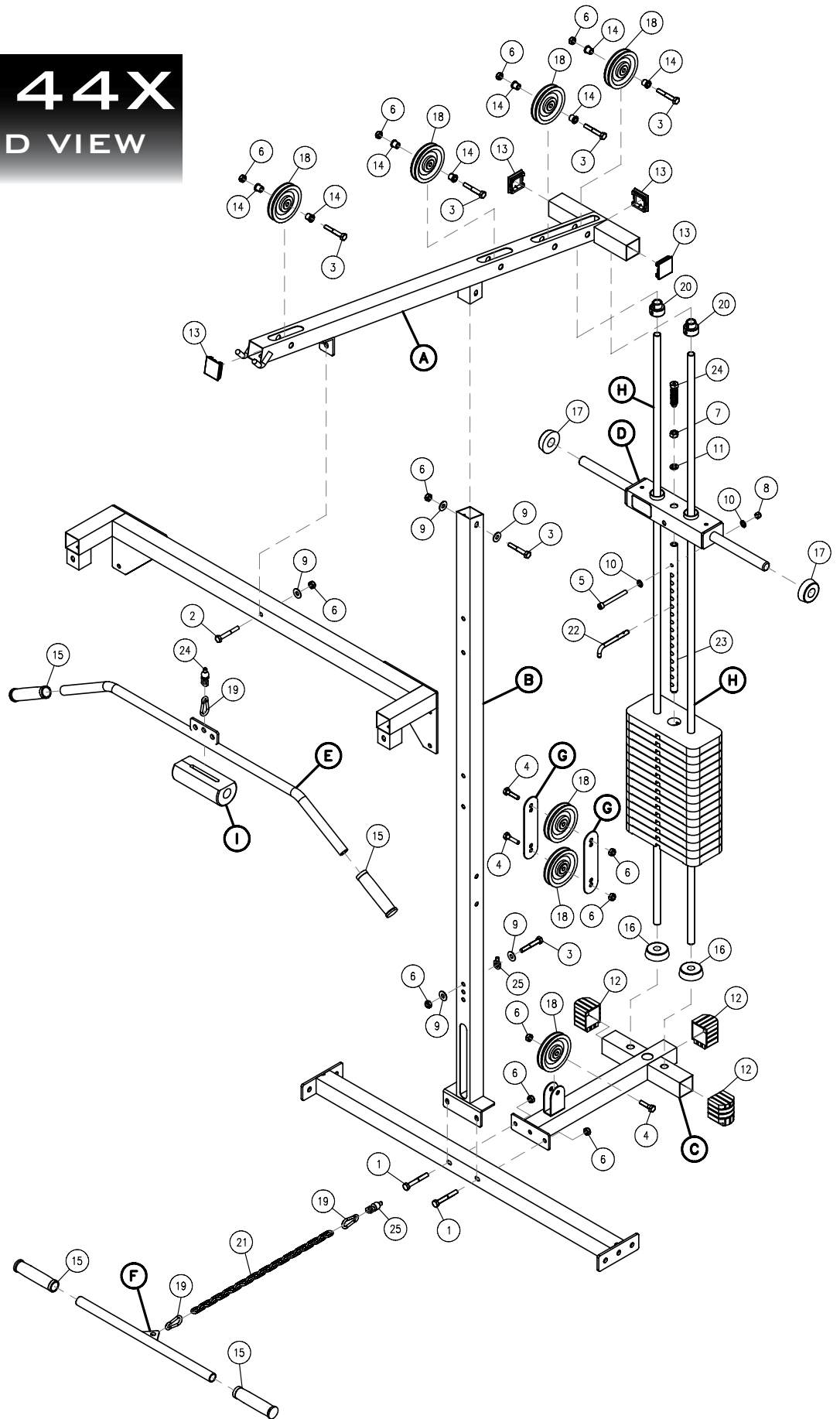

# PLA 144X

NOTES



**PLA144X**

PLEASE WRITE YOUR SERIAL NUMBER IN THE BOXES BELOW

S/N # 001596-□□-□□-□□□□-□□□□

*Body-Solid*®  
Built for Life

1900 S. DES PLAINES AVE.  
FOREST PARK, IL 60130  
PHONE:(708)427-3555  
FAX:(708)427-3556  
HOURS: M-F 8:30 - 5:00 CST

[www.bodysolid.com](http://www.bodysolid.com)

The contact information is presented in a clean, black, sans-serif font on a light grey background. The logo and tagline are in a white, cursive font on a black background.

© Copyright 2011. Body-Solid. All rights reserved. Body-Solid reserves the right to change design and specifications when we feel it will improve the product. Body-Solid machines maintain several patented and patent pending features and designs. All rights reserved on all design patents and utility patents.